

DRAINPRO®

Commercial Drainage Solutions

**HYGIENE
PERFORMER**

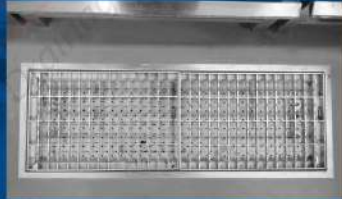



In today's food service environment, getting rid of hot water, grease and organic waste is very challenging. Proper drainage system in place is very important since inception of project. Failing to do create problems like drainage blockages, foul smell, unhygienic working condition, food contamination, etc. Install commercial drainage solution which optimise food safety, health and safety of employees and the protection of water.

HYGIENIC PERFORMER

DRAIN TROUGH

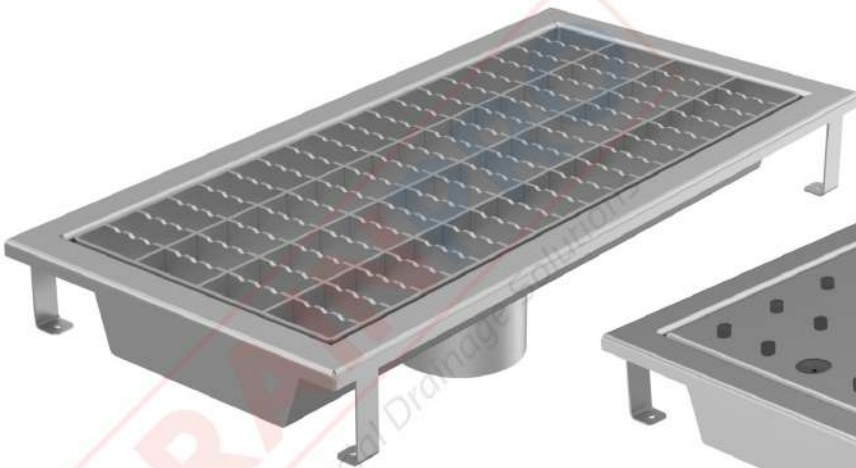

ANTI-SKID COVER



PERFORATED COVER

Drain trough is used for drainage of water on floor. It is grouted in floor during civil work and pipes are connected to bottom of trough. It is highly effective and proven product for drainage. It enables hygienic work environment, odour free kitchen, easy water drainage, and blocks soiled food particles. It is majorly used as point drain system. Drain trough is made from all Stainless Steel corrosion free material & provides 3 stage filter process.

STANDARD SIZES (in mm)	OUTLET DIA.
300 x 300 x 75 + 75	100mm Dia. X 75 mm ht
600 x 300 x 75 + 75	
900 x 300 x 75 + 75	
900 x 500 x 75 + 75	

Drain Trough Parts

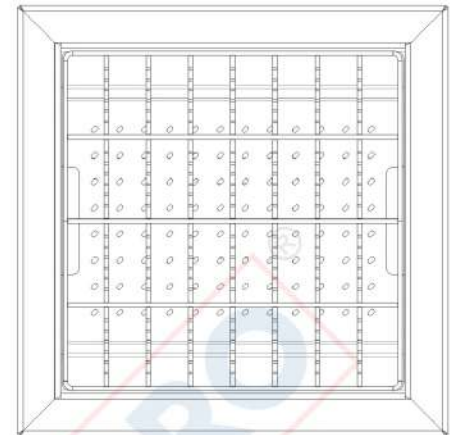
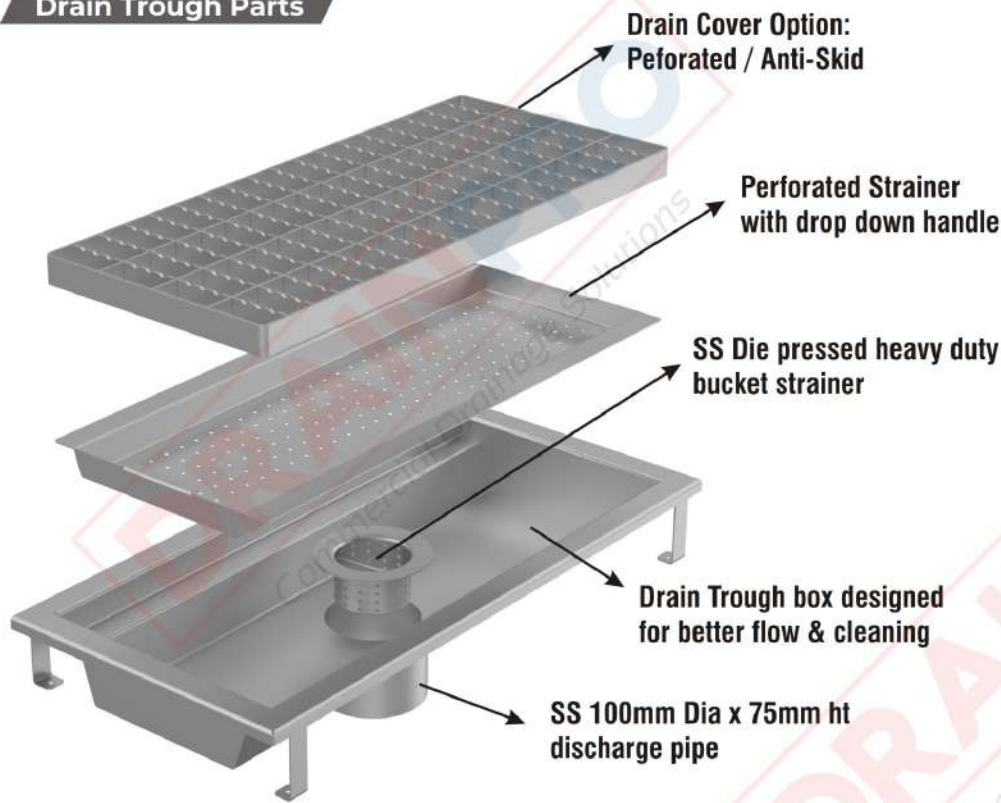

Top View

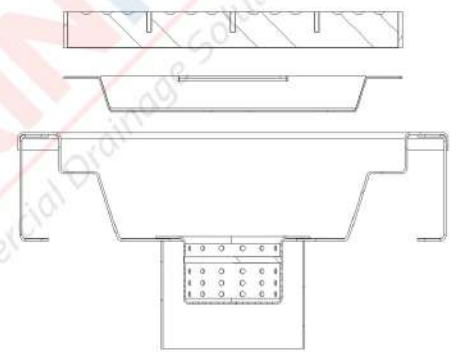

Front View

Drain Trough Specification

- Trough fabricated from SS 16swg, 304 grade with unique tapered design for better discharge of water and cleaning of trough.
- Discharge section is die pressed for better flow of water.
- Die pressed heavy duty perforated bucket strainer.
- Center perforated strainer fabricated from SS 19g, 304 grade with handle
- Drain Cover option available in Perforated Drain Cover / Anti-Skid

Drain Trough With Slot Channel



Specially designed to install outside cold room doors, for easy trolley movement.

TRENCH COVERS

DRAINPRO[®]

Commercial Drainage Solutions

TRENCH COVER is used for discharge of water where in drain trench is made from civil work and top is closed with Steel drain covers. It enables hygienic work environment, odour free kitchen, easy water drainage, and blocks soiled food particles. Trench Cover is made from all Stainless Steel corrosion free material. It is used at various places like Ho-Re-Ca Kitchens, Pharma & Chemical Plants, Food processing plants, dairy plants, brewery, etc. It can be used as Point drain or continuous drain trench. TRENCH COVERS are available in various options like Perforated, Anti Skid, Trench Cover with Strainer & Angle frame.

Trench Cover With Strainer

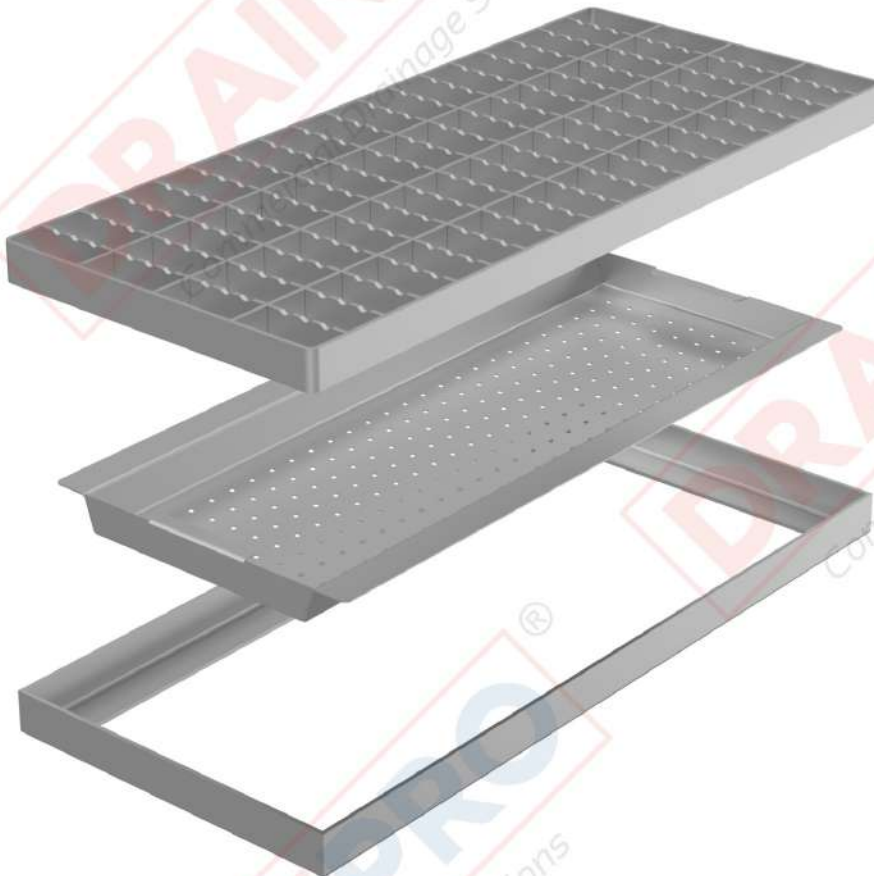

STANDARD SIZES FOR TRENCH COVERS

246 x 246 x 25mm

546 x 246 x 25mm

846 x 246 x 25mm

Anti-skid Drain Grating

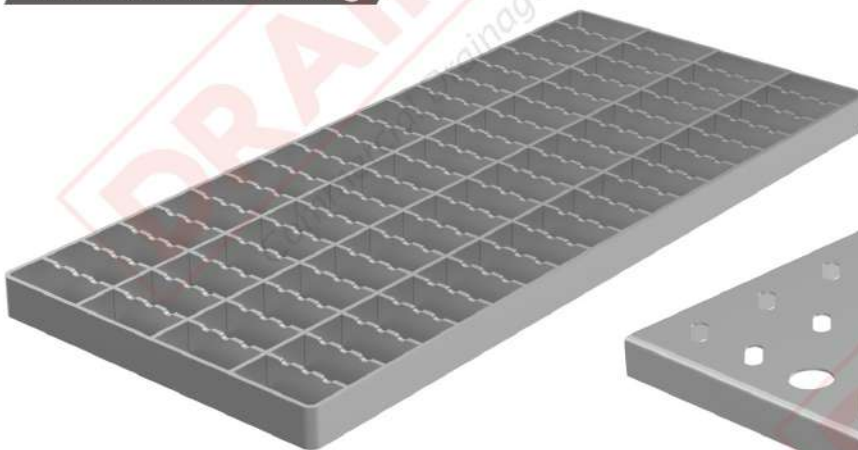

Perforated Trench Cover

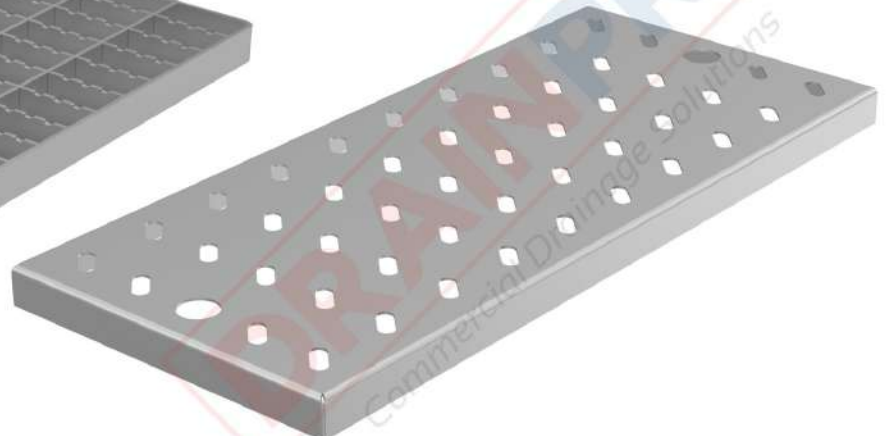

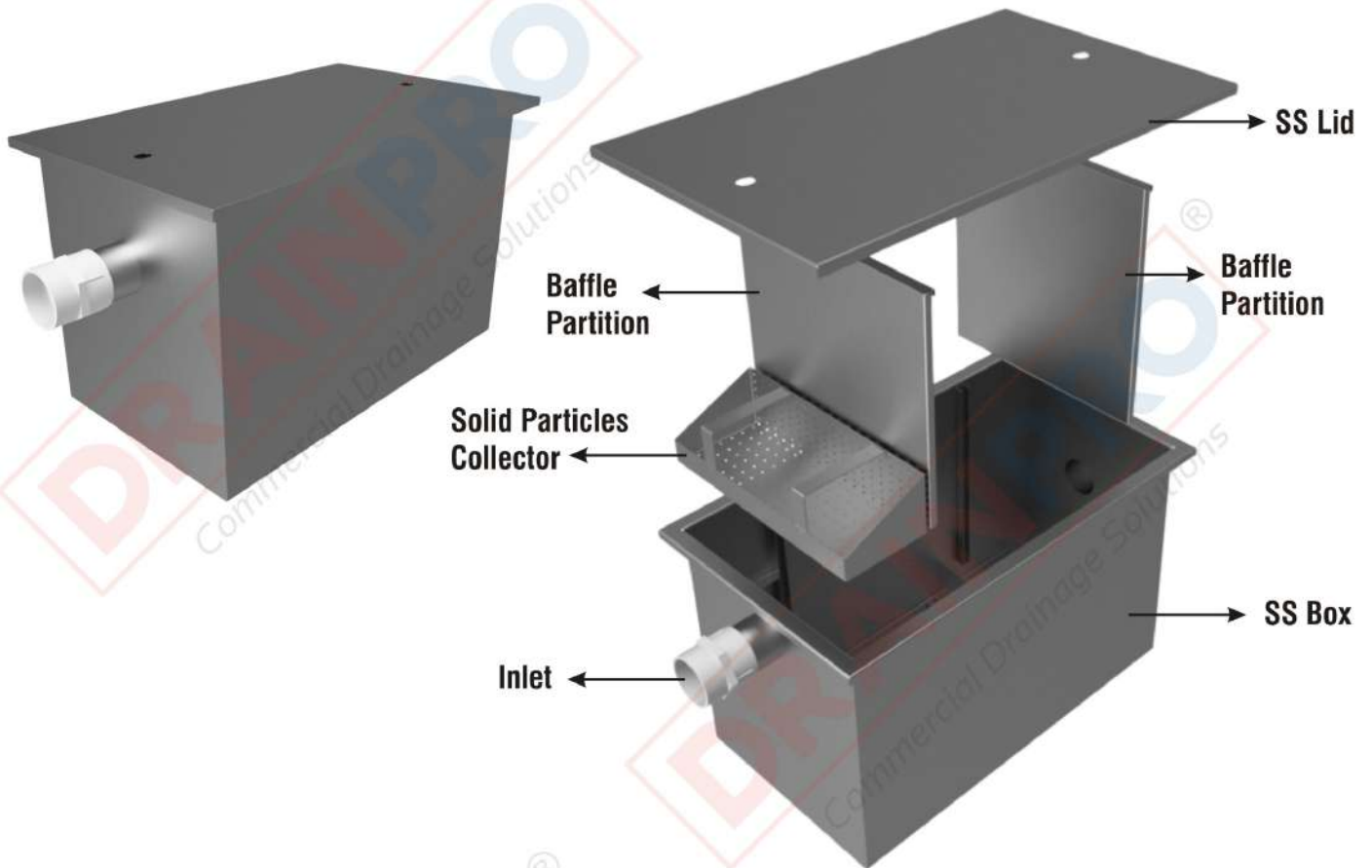

Main Features

- Fully manufactured from non-corrosive material
- Removable SS strainer to collect solid waste
- Fully welded and leak proof body for hygiene
- Removable lid and baffles for easy cleaning
- Available in different sizes

Construction

- Main body and Lid made from 1.5 mm polished stainless steel AISI 304
- Removable baffles made from 1.2 mm polished stainless steel AISI 304
- 75 mm diameter inlet and outlet pipe fully welded to body
- PVC coupling for easy pipe connection
- Strainer with handle made from polished 1.2 mm stainless steel AISI 304

GREASE CHAMBER SIZES

SR.NO.	Holding Capacity Model No. (Ltrs)	Top Length x Top Width (L x W)	Total Height (H)	Tank Length x Tank Width (L1 x W1)	Total Length (L2)	Inlet Height (H1)	Outlet Height (H2)	Inlet/Outlet Size (D/D1) mm
1	75	750 x 450	450	685 x 385	965	363	288	75 / 75
2	59	600 x 450	450	485 x 385	765	363	288	75 / 75
3	20	500 x 400	300	435 x 335	715	213	138	75 / 75

All dimensions are in mm.

DEALERS / EXPORT INQUIRIES SOLICITED

JANSHAKTI[®]
Professional Kitchen Experts

Striving for Excellence

OUR BRANDS

FROSTPRO[®]

Hospitality Cooling Experts

Exclusive Refrigeration Equipment

DRAINPRO[®]

Commercial Drainage Solutions

Office & Showroom : 49, Chirag Diamond Estate, Beside Pushkar Business Park, Nr. D-Mart, Bapunagar, Ahmedabad-24, Gujarat (India).

Works : Bakrol Bujrang, Ahmedabad, Gujarat 382433.

Experience Center : G.F. Shop No. 11 & 12, Swati Clover, Near Shilaj Circle, Beside Yanki Sizzlers, S.P. Ring Road, Thaltej, Ahmedabad, Gujarat 380054 (INDIA)

📧 sales@janshaktiindia.com | projects@janshaktiindia.com

🌐 www.janshaktiindia.com

☎ **+91 9574001797 | 9574001796 | 9624866366 | | 8488851795**

Proud Member of...



To know more about us

